

CONTINENTAL NH3 PRODUCTS
INSTALLATION, OPERATION, REPAIR & MAINTENANCE INSTRUCTIONS

PRODUCT SERIES: A-MVD A-SVD

ATTENTION: Please follow all of the instruction in this manual carefully and read the entire manual completely, failure to do so may cause the product to function improperly or fail causing serious injury or death.

DANGER  **DANGER**

ANHYDROUS AMMONIA IS AN INHALATION HAZARD AND WILL CAUSE SERIOUS INJURY OR DEATH. PLEASE USE EXTREME CAUTION WHEN HANDLING IT OR PERFORMING ANY MAINTENANCE ON EQUIPMENT USED FOR ANHYDROUS AMMONIA.

ATTENTION: Before performing any installation, repair or maintenance please follow the instructions below.

1. You must be certified to work with anhydrous ammonia. If you are not please seek out the appropriate agricultural department to attend a class to obtain the proper certification.
2. Wear appropriate safety goggles, gloves and breathing apparatuses.
3. Drain all tanks, hoses and piping of anhydrous ammonia **COMPLETELY** before removing, installing, performing maintenance or repairing any equipment.
4. Always remove device from service before performing any maintenance or repair
5. have sufficient water near by
6. Obey all local, state and federal laws regarding the handling of anhydrous ammonia

INSTALLATION & OPERATION

1. See following pages for complete installation instructions and operational instructions

MAINTENANCE

1. Check manifold regularly for leaks and wear.
2. If manifold is leaking from any pipe threads try tightening the hose barb and putting more thread sealant on the pipe threads. Be careful not to over tighten because you may crack the casting. If casting cracks see drawing break down a replace appropriate part.
3. If manifold leaks from the ring MVD-3, body MVD-01 or gauge adaptor MVD-7 install a repair kit or replace manifold.

REPAIR

1. Remove valve from service by following the above ATTENTIONS AND CAUTIONS.
2. Remove gauge adaptor MVD-7 from manifold body and replace o-ring MVD- in gauge adaptor
3. Remove upper body MVD-01 and outlet ring MVD-3 and replace the upper o-ring MVD- and lower o-ring MVD- in the MVD-3.
4. Replace MVD-3 onto the lower body MVD-2 with stamping side up and replace the upper body MVD-01 onto the outlet ring MVD-3.
5. Screw on the gauge adaptor MVD-7 onto the stem of the MVD-2 and tighten gently. Do not over tighten because the stem MVD-6 may brake.
6. Reinstall manifold back into service by following the installation instructions.

QUESTIONS CALL 800-537-5642

Catalog
Number

Description

A-MVD-CORN VERTICAL DAM MANIFOLD REPAIR PARTS

A-407	PRESSURE GAUGE - 150# - 1/4" MPT - 2-1/2" DIAL
A-SVD-C	CORN BODY ONLY LESS RING
SVD-01	SEPARATOR BODY
SVD-2-C	CORN VERTICAL DAM BODY INCLUDES SVD-6-C
SVD-3-C	CORN RING ONLY (SPECIFY NUMBER OF OUTLETS AND APPLICATION RATES) 3-13 OUTLETS
SVD-6-C	STUD FOR CORN MANIFOLD
SVD-7	GAUGE ADAPTOR
SVD-8115	GAUGE ADAPTOR SEAL
SVD-8149	SEPARATOR RING SEAL (TOP)
SVD-8150	SEPARATOR RING SEAL (BOTTOM)
SVD-9	INLET HOSE BARB 1" MPT X 1" HOSE
SVD-RK	REPAIR KIT, INCLUDES - SVD-8115, SVD-8145, SVD-8150

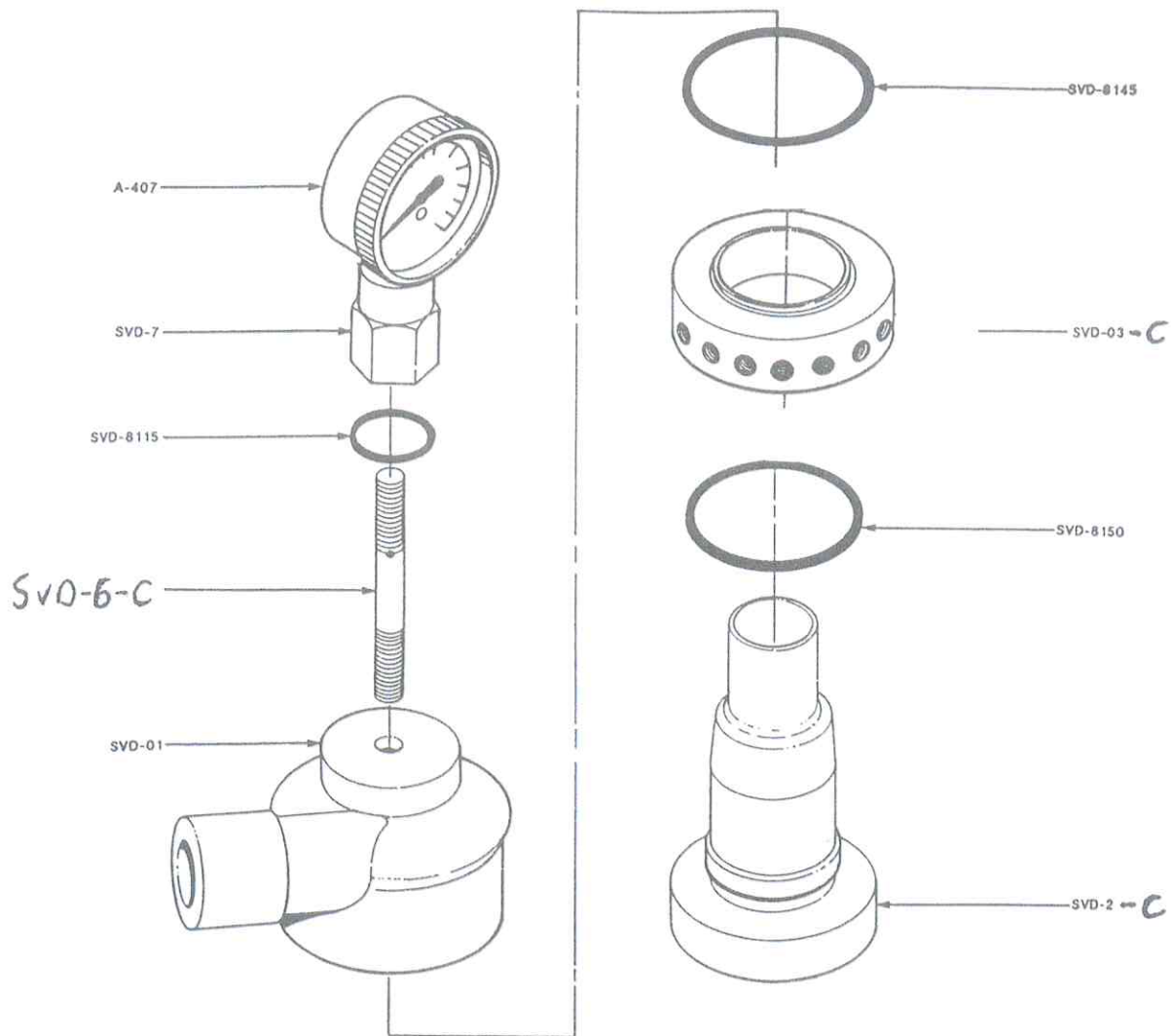

CONTINENTAL NH 3 PRODUCTS CO., INC.

Catalog
Number

Description

A-MVD VERTICAL DAM MANIFOLD REPAIR PARTS

A-407	PRESSURE GAUGE - 150# - 1/4" MPT - 2-1/2" DIAL
A-MVD	BODY ONLY
MVD-01	MANIFOLD BODY
MVD-2	VERTICAL DAM BODY INCLUDES MVD-6
MVD-3	DISTRIBUTOR RING 3-16 OUTLETS
MVD-6	STUD
MVD-7	GAUGE ADAPTOR
MVD-8	INLET HOSE BARB 3/4" MPT X 1" HOSE
MVD-8121	GAUGE ADAPTOR SEAL
MVD-8142	DISTRIBUTOR RING SEAL (TOP)
MVD-8144	DISTRIBUTOR RING SEAL (BOTTOM)
MVD-RK	REPAIR KIT INCLUDES - MVD-8121, MVD-8144, MVD-8142

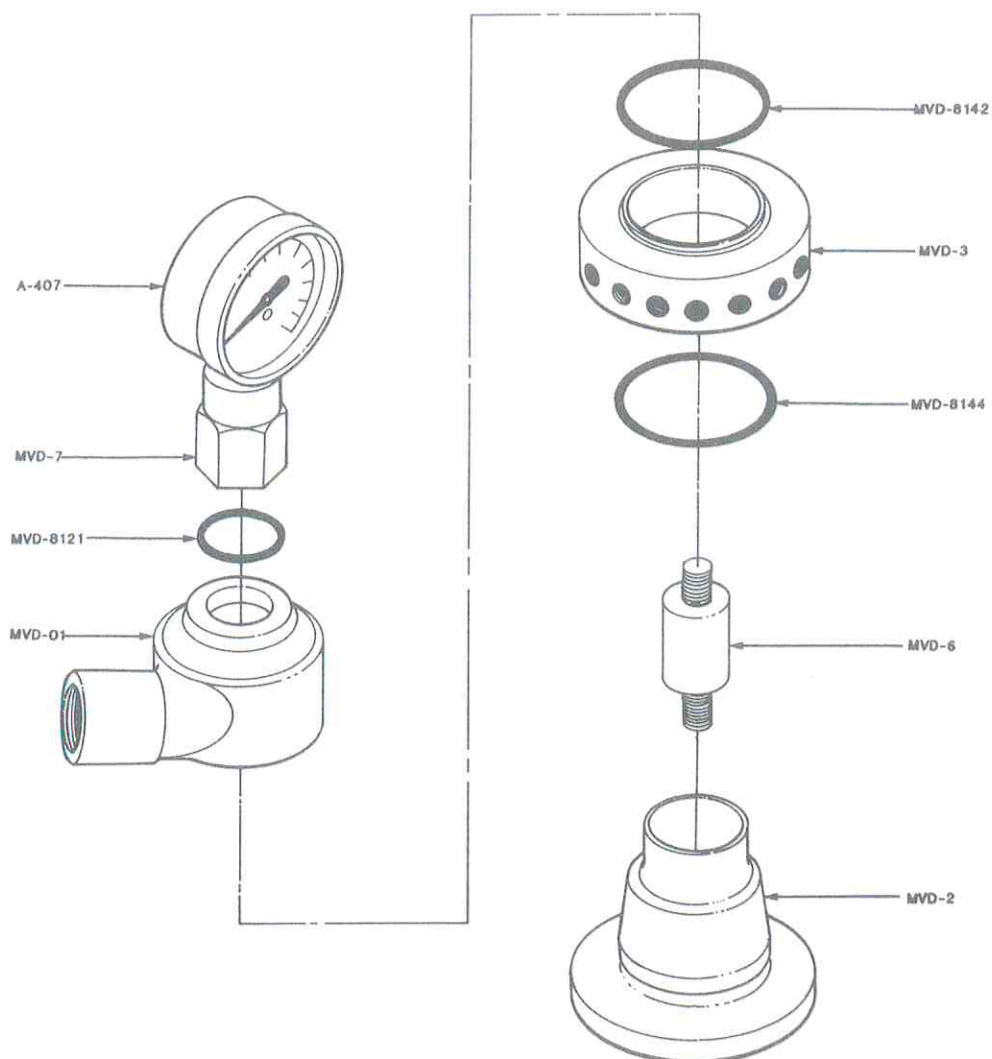

CONTINENTAL NH 3 PRODUCTS CO., INC.

Catalog
Number

Description

A-SVD VERTICAL DAM SEPARATOR REPAIR PARTS

A-SVD	SEPARATOR BODY ONLY LESS RING
SVD-01	SEPARATOR BODY
SVD-03	THREE OUTLET DIVIDER RING
SVD-04	FOUR OUTLET DIVIDER RING
SVD-05	FIVE OUTLET DIVIDER RING
SVD-2	SEPARATOR VERTICAL BODY INCLUDES SVD-6
SVD-6	STUD
SVD-7	GAUGE ADAPTOR
SVD-8	OUTLET ORFICED HOSE BARB 1/2" MPT X 1" HOSE
SVD-8115	GAUGE ADAPTOR SEAL
SVD-8149	SEPARATOR RING SEAL (TOP)
SVD-8150	SEPARATOR RING SEAL (BOTTOM)
SVD-9	INLET HOSE BARB 1" MPT X 1" HOSE
SVD-RK	REPAIR KIT, INCLUDES - SVD-8115, SVD-8145, SVD-8150

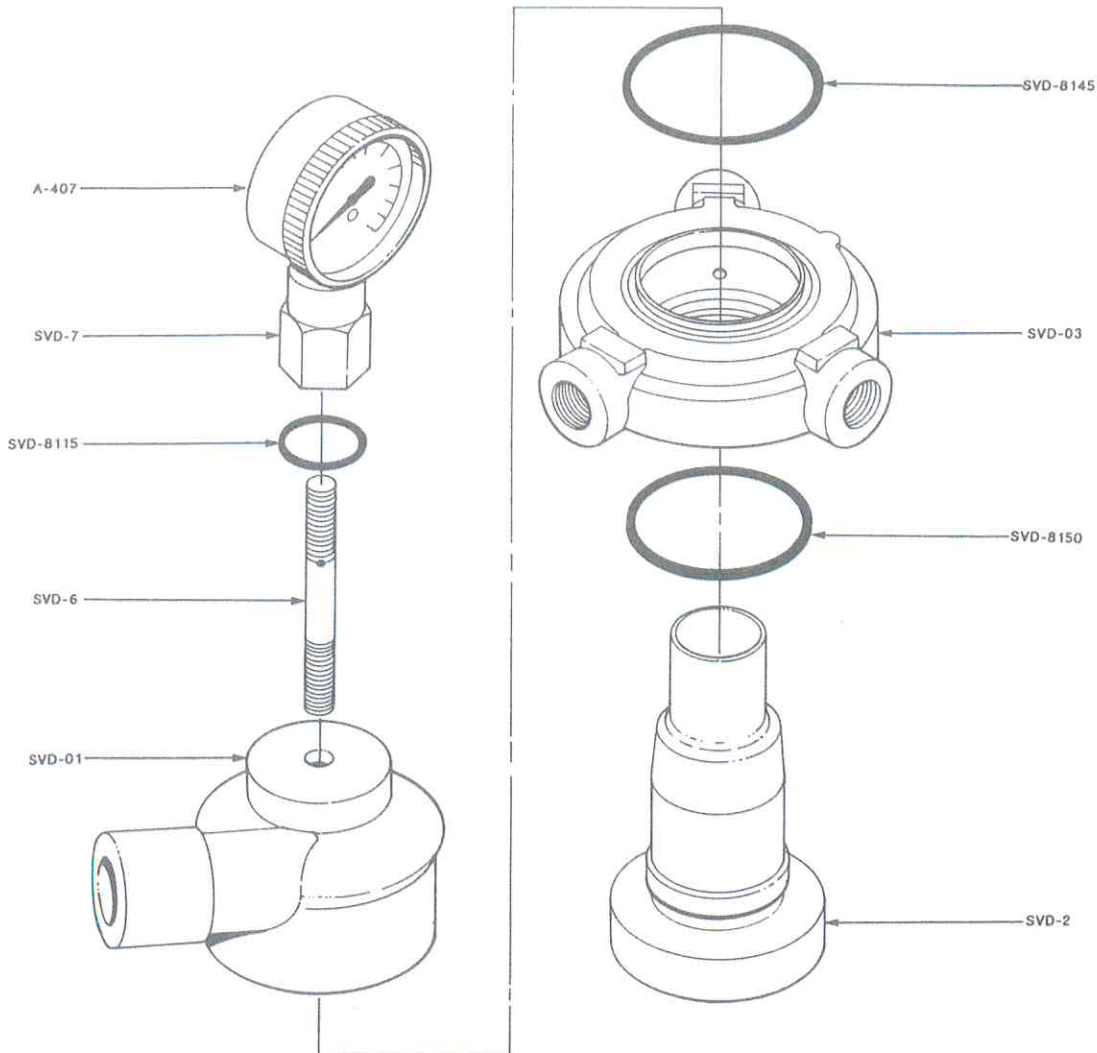

CONTINENTAL NH 3 PRODUCTS CO., INC.



INSTALLATION INSTRUCTIONS

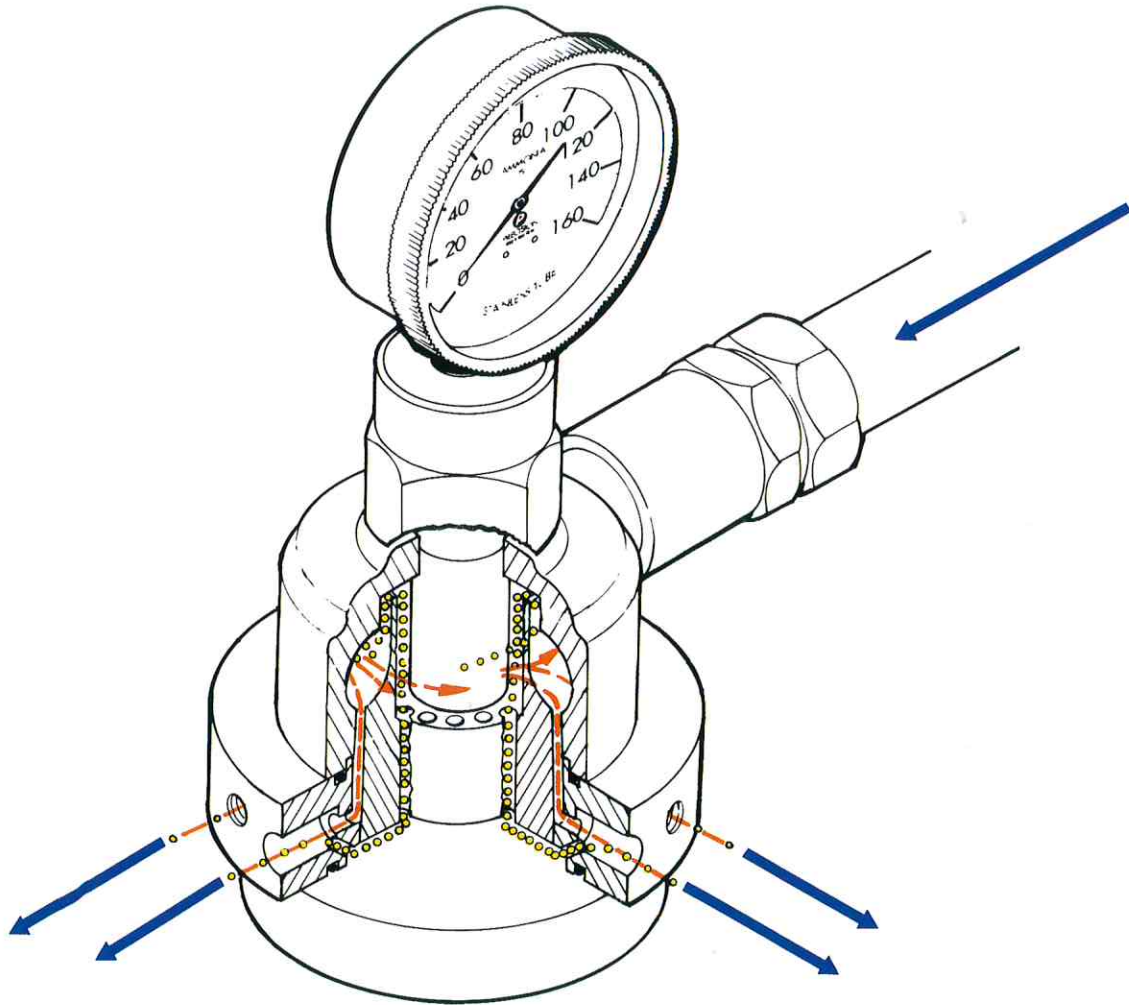

-  AMMONIA
-  LIQUID
-  VAPOR

CONTINENTAL NH₃ PRODUCTS



Congratulations! You have just purchased the latest design in NH₃ distribution manifolds. So what makes the Vertical Dam Manifold system the finest that Continental has ever produced? Well, until now, all manifolds have failed to address the real villain in distribution: VAPOR. The A-MVD manifolds in conjunction with the A-SVD separator effectively deal with the Vapor Villain and thus promote an even distribution of NH₃ across the entire swath.

Anhydrous Ammonia, by its very nature, is a mixture of vapor and liquid when it leaves the nurse tank and enters your metering system. For example, tests demonstrate that at 15# of manifold pressure, you could have a resulting vapor volume of 80% to 90% ! This vapor wreaks havoc with distribution. One manifold port may be blocked by the vapor while the next port gets mostly liquid. The net result is that some rows of your field will get too much ammonia while others will get next to none. The VAPOR VILLAIN wants to burn one row of crops and then starve the next!

Continental's revolutionary Vertical Dam concept (patent pending) temporarily separates a substantial amount of vapor from the liquid. This gives the liquid a chance to evenly distribute to each liquid orifice before the separated vapor rejoins it through individual vapor orifices. In this way, the Vapor Villain is effectively neutralized, and an even distribution to each applicator hose is greatly enhanced.

Important information: The higher the manifold pressures (up to 65% of tank pressure) the better. Manifold efficiency peaks at 65% of tank pressure. Surpassing 65% will not produce any better results.

INSTALLATION INSTRUCTIONS

1. Tool bars requiring 2 manifolds can effectively split the ammonia flow by using a 1" 3000# pipe tee.
2. Tool bars requiring 3 or 4 manifolds must use the A-SVD separator to divide the flow into equal parts.
3. Mount the A-MVD manifold(s) and A-SVD separator so that the outlets are on a horizontal plan. Space manifolds as evenly as possible.
4. 1" female NPT swivel connections are provided with each manifold and separator for ease of connection.
5. Continental recommends that 1" reinforced EVA hose with a minimum working pressure of 150 PSI be used to connect the meter to the separator or tee and, also, to connect the tee or separator to the manifolds. Hoses connecting the tee or separator to the manifolds should be of equal lengths.

CONTINENTAL NH₃ PRODUCTS



DANGER: Do not install any regulating or shutoff device down stream of the meter. Such a device will trap ammonia in the connecting hoses and cause them to burst and in turn cause severe personal injury or even death!

6. All hoses from the manifolds to the knives should be of equal lengths.

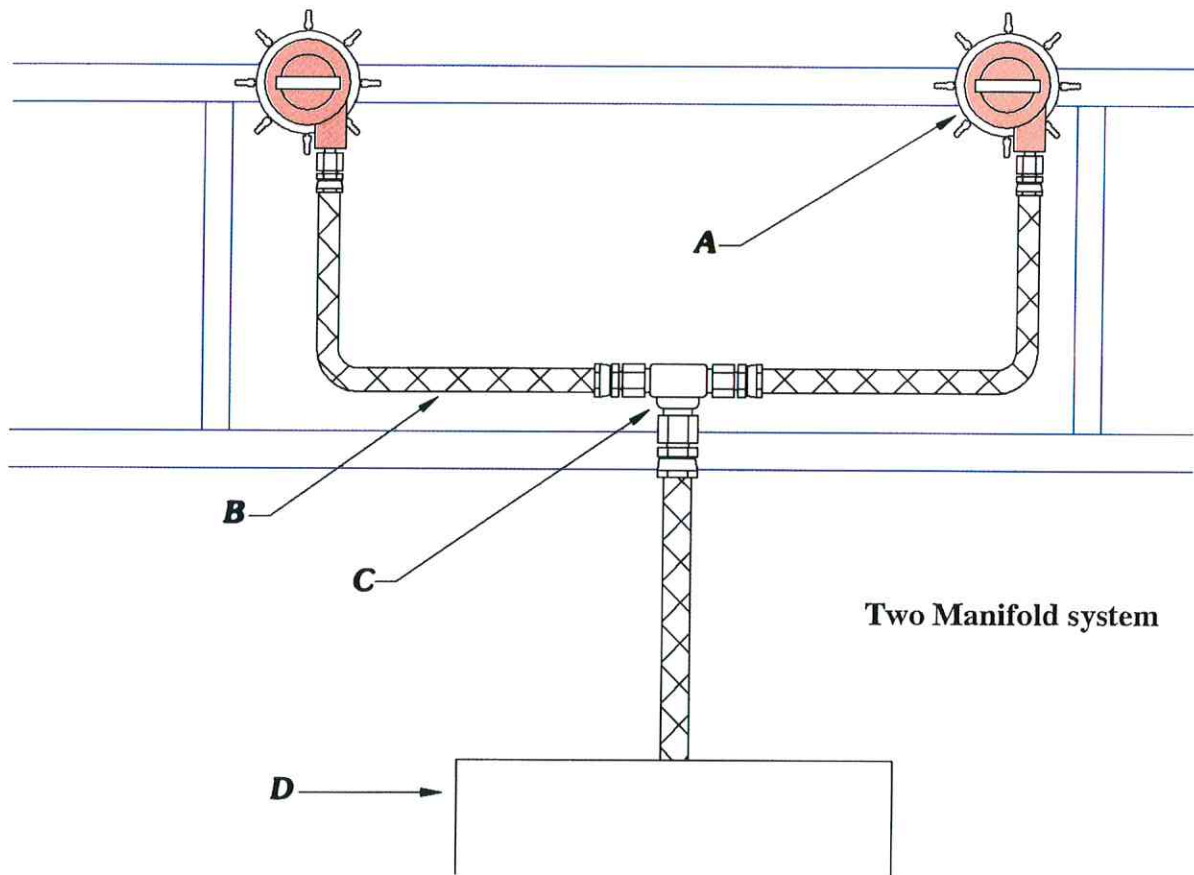

- (A) A-MVD manifold
- (B) 1" reinforced 150 PSI eva hose
- (C) 1" pipe tee
- (D) Meter

CONTINENTAL NH3 PRODUCTS

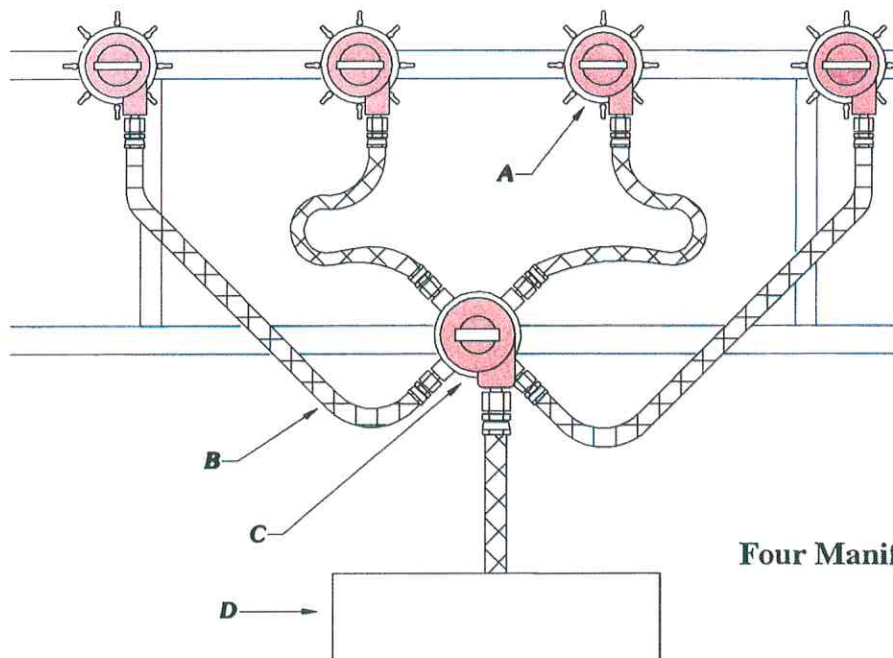
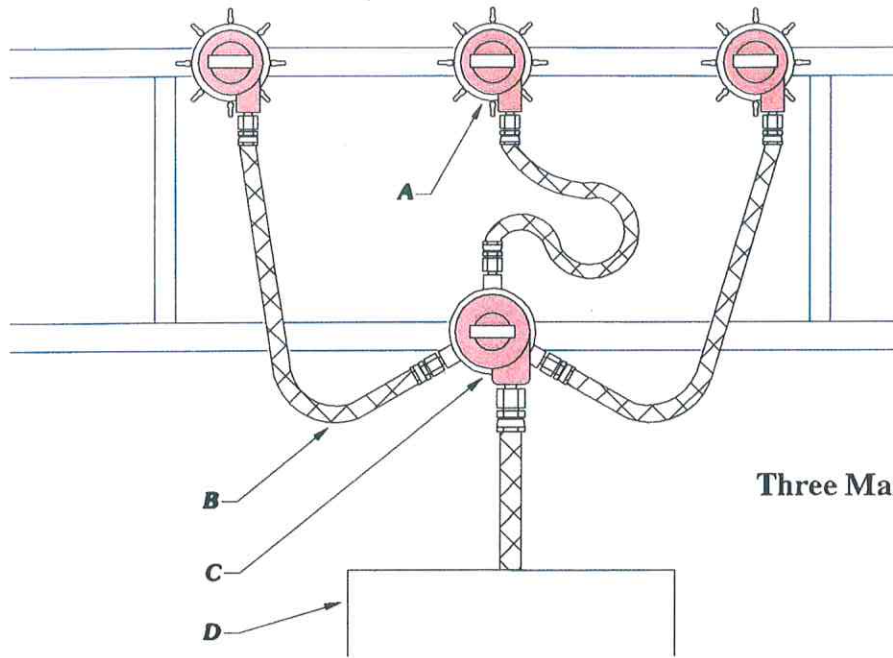

- (A) A-MVD manifold
- (B) 1" reinforced 150 PSI eva hose
- (C) A-SVD separator
- (D) Meter

CONTINENTAL NH₃ PRODUCTS

A-MVD Manifold System

WHEN IS A TEE NOT A TEE?

A tee is not a tee when you plumb an A-MVD manifold system incorrectly!!! An Incorrectly plumbed tee will cause one manifold to get as much as 80% while the other will be starved to as little as 20%. Continental NH₃ Products specifically disclaims any express or implied warranty if the A-MVD system is plumbed incorrectly. To avoid such problems, simply follow the diagram below.

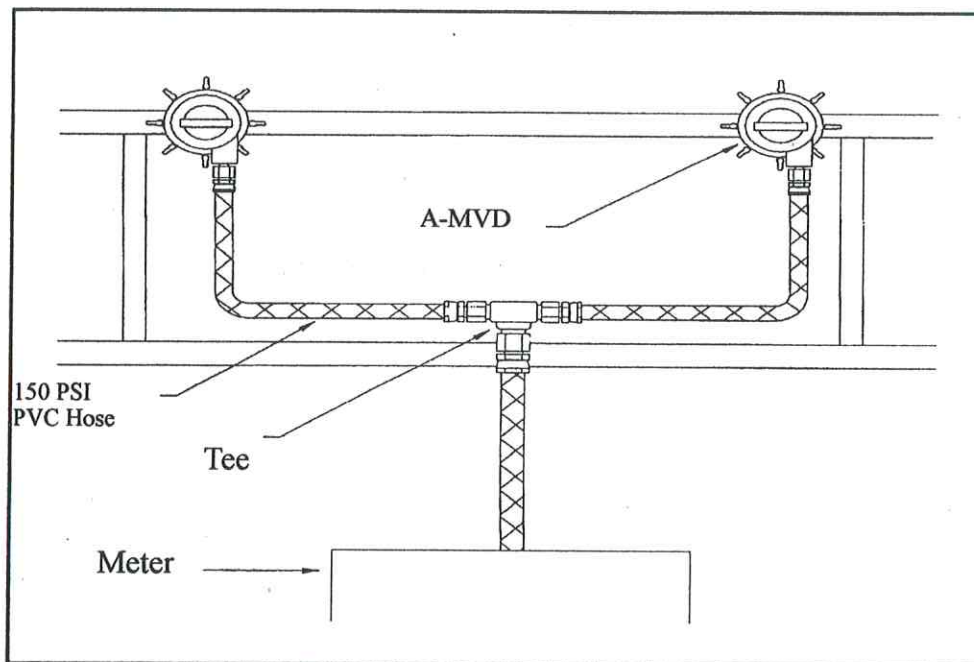

A-MVD System with two (2) manifolds and a tee.

See backside for important information and additional warranty information.

QUESTIONS AND ANSWERS

QUESTION: My applicator system requires a regulating or shutoff device downstream of the meter. What should I do about hose connections?

ANSWER: When there is a shutoff or regulating device downstream of the meter, high pressure ammonia hose or schedule 80 piping must be used between the meter and the device. The ammonia hose must have a minimum working pressure of 350 PSI (1750 PSI burst rating) and be approved for ammonia service.

QUESTION: Can additives in the ammonia deteriorate the aluminum in these manifolds?

ANSWER: Yes! It has been our experience that additives, such as N-Serve, not only corrode aluminum but also leave crystal-like deposits which could eventually clog up the orifices.

To avoid problems, disassemble and thoroughly clean the manifolds at the end of each application season. Some people have had success in keeping the manifolds clean by soaking them in new or used motor oil.

**APPLICATORS
APPLYING RATES AT
60 #N OR BELOW
SHOULD RUN AS FAST
AS POSSIBLE**

DISCLAIMER: Continental NH₃ cannot warranty any manifold that has failed due to being clogged up or corroded by additives in the ammonia.
